

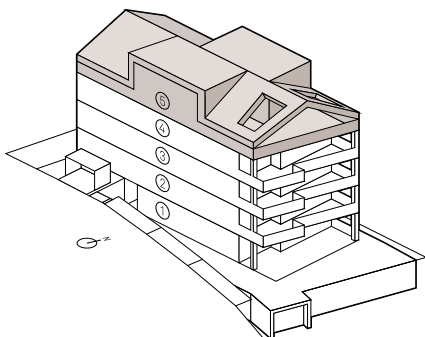

SCHÜTZENWEG

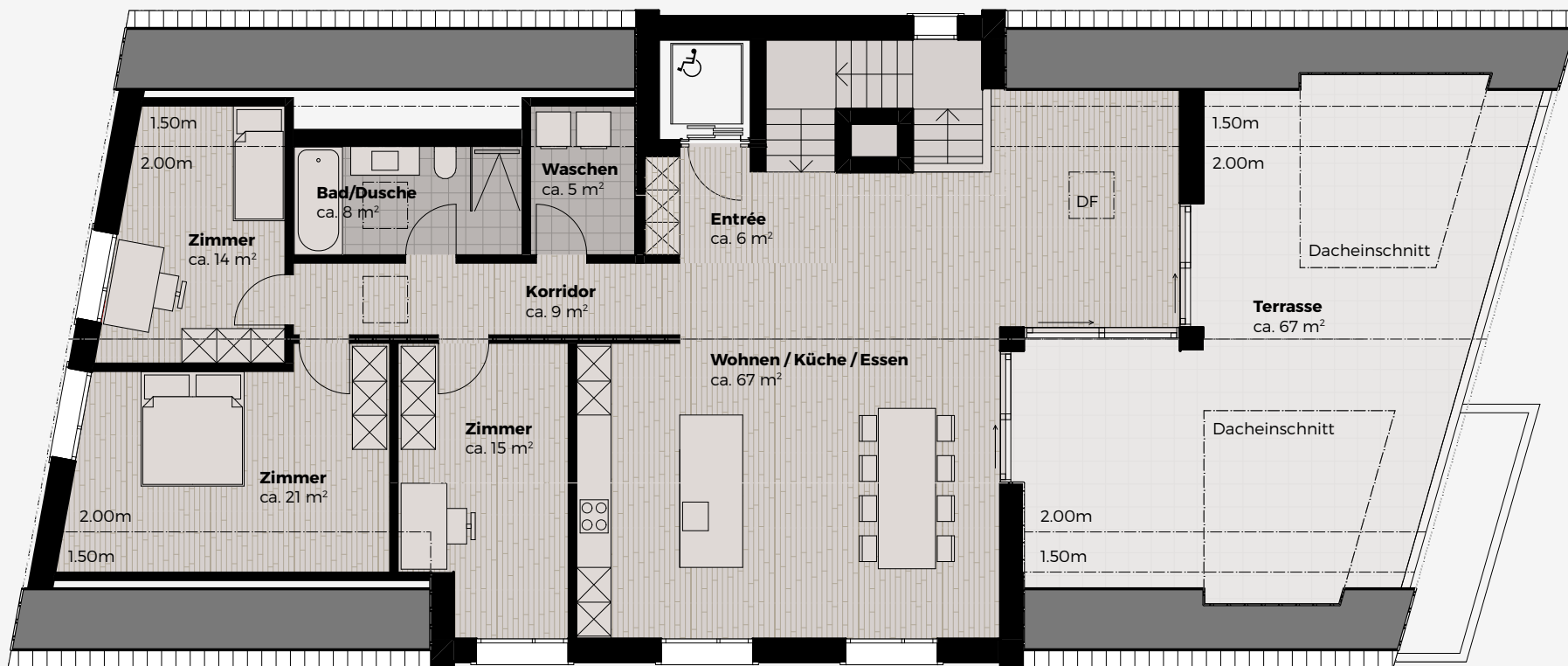

LEVEL 5 4.5 ZIMMER WOHNUNG

Wohnfläche	ca. 154 m ²
Terrasse	ca. 67 m ²
Waschen	ca. 5 m ²
Dispo/Hauswirtschaft	ca. 8 m ²



allreon AG, Bruchstrasse 33, CH-6003 Luzern
Tel. +41 41 630 11 22, info@allreon.ch, www.allreon.ch





SCHÜTZENWEG

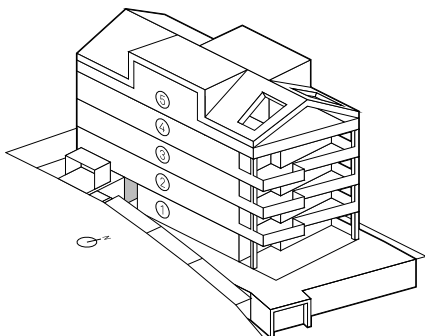
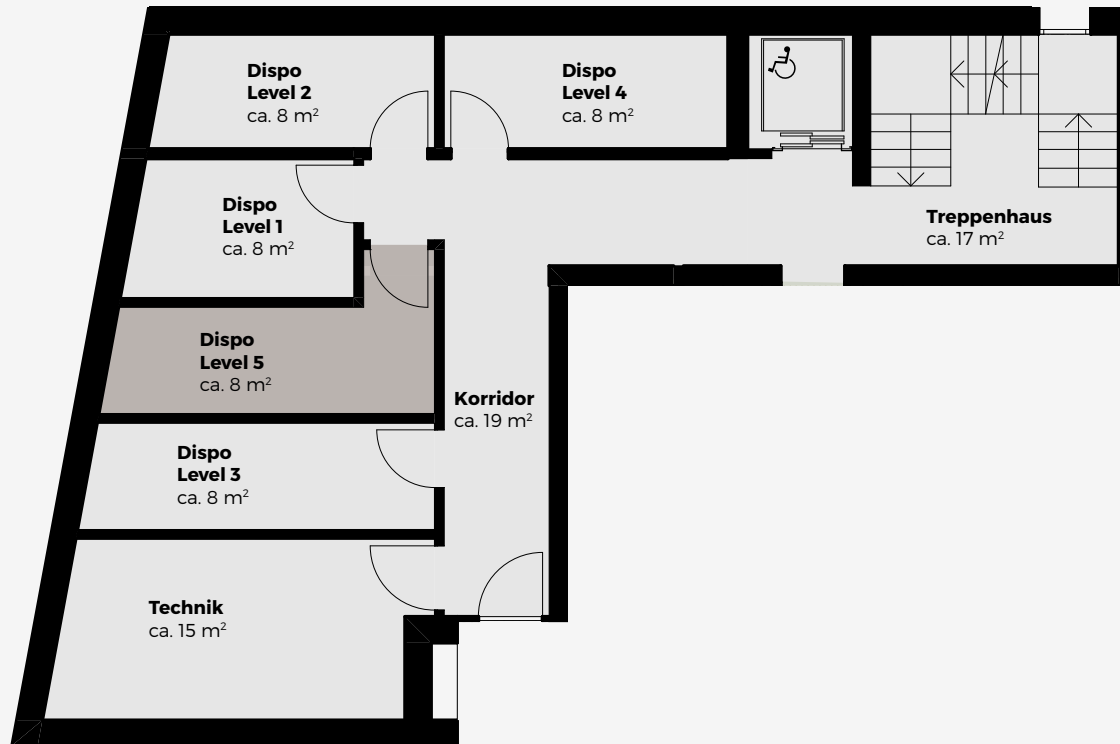

LEVEL 1 DISPO NEBENRÄUME



allreon AG, Bruchstrasse 33, CH-6003 Luzern
Tel. +41 41 630 11 22, info@allreon.ch, www.allreon.ch





SCHÜTZENWEG

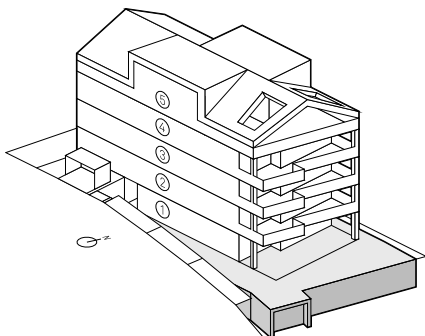
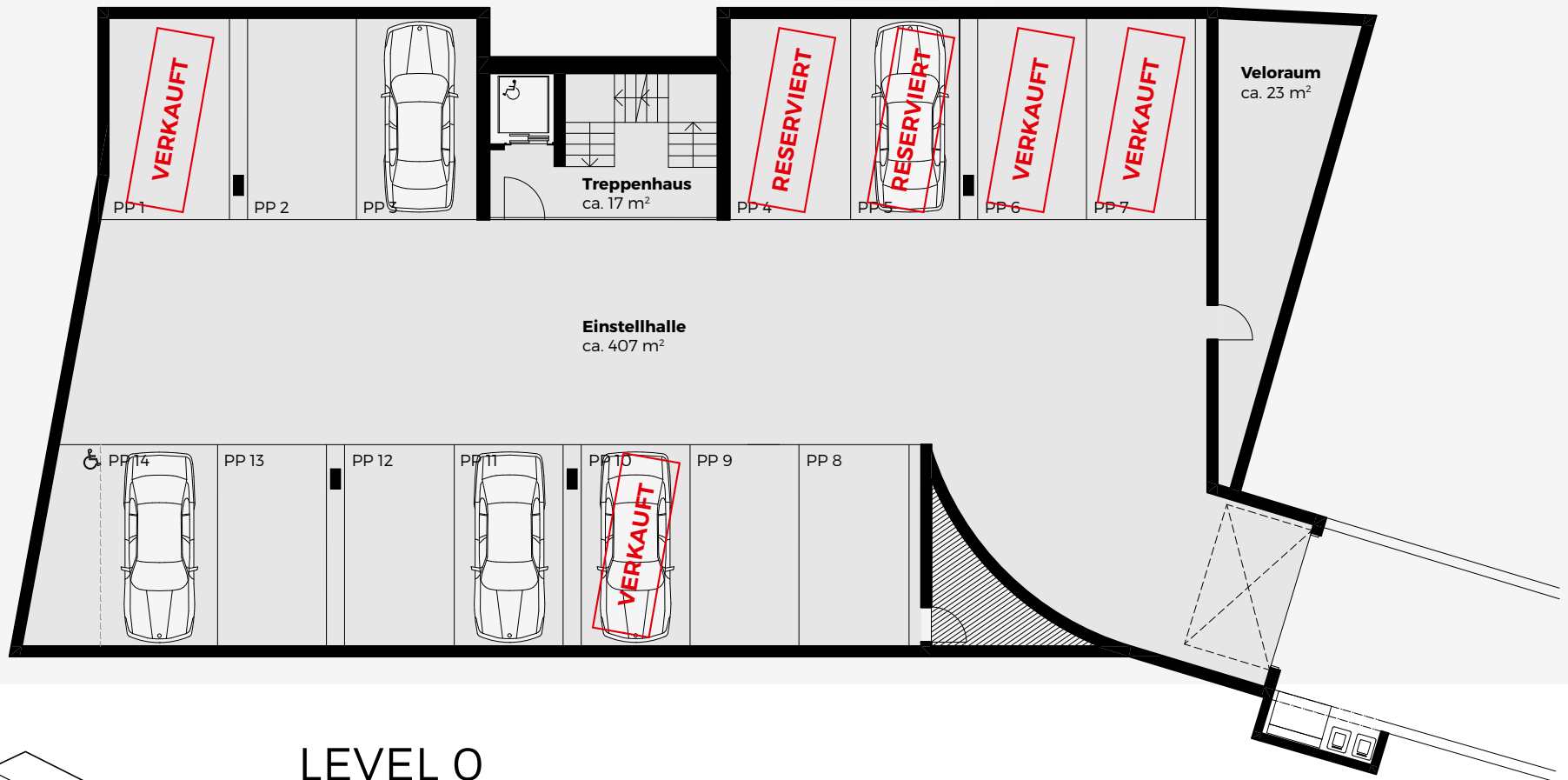

LEVEL 0 EINSTELLHALLE



allreon AG, Bruchstrasse 33, CH-6003 Luzern
Tel. +41 41 630 11 22, info@allreon.ch, www.allreon.ch

